



Orifice Plates

Series OFC Flow Type Orifice Plates

When ordering please specify:

- Series Number
- Line Size & Schedule
- Material
- Quantity
- Required Orifice Size

Material

- 316 Stainless Steel
- Hastelloy - Monel
- Other Material Available

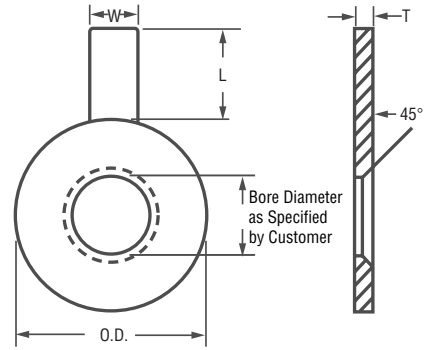

Plates fit ANSI flanges up to 24". Orifice plates for line sizes larger than 24" are available. Consult factory for dimensions.

Line Size	All Ratings					Weight in pounds - Blank Plate							
	150# O.D.	300# O.D.	600# O.D.	900# O.D.	1500# O.D.	T	W	L	150#	300#	600#	900#	1500#
1/2"	1.875	2.125	2.125	2.500	2.500	0.125	1.00	4.00	.2	.2	.2	.3	.3
3/4"	2.250	2.625	2.625	2.750	2.750	0.125	1.00	4.00	.3	.3	.3	.3	.3
1"	2.625	2.875	2.875	3.125	3.125	0.125	1.00	4.00	.3	.4	.4	.5	.5
1-1/2"	3.375	3.750	3.750	3.875	3.875	0.125	1.00	4.00	.5	.5	.5	.6	.6
2"	4.125	4.375	4.375	5.625	5.625	0.125	1.00	4.00	.6	.7	.7	1.0	1.0
2-1/2"	4.875	5.125	5.125	6.500	6.500	0.125	1.00	4.00	.8	.9	.9	1.3	1.3
3"	5.375	5.875	5.875	6.625	6.875	0.125	1.00	4.00	1.0	1.1	1.1	1.4	1.5
4"	6.875	7.125	7.625	8.125	8.250	0.125	1.00	4.00	1.5	1.6	1.8	2.0	2.1
5"	7.750	8.500	9.500	9.750	10.000	0.125	1.00	4.00	1.9	2.2	2.7	2.9	3.0
6"	8.750	9.875	10.500	11.375	11.125	0.125	1.00	5.00	2.4	3.0	3.4	3.9	3.7
8"	11.000	12.125	12.625	14.125	13.875	0.125	1.00	5.00	3.6	4.4	4.8	5.9	5.7
10"	13.375	14.250	15.750	17.125	17.125	0.125	1.00	5.00	5.3	6.0	7.3	8.6	8.6
12"	16.125	16.625	18.000	19.625	20.500	0.250	1.25	5.00	8.1	8.6	10.0	11.7	12.8
14"	17.750	19.125	19.375	20.500	—	0.250	1.25	5.00	11.0	11.7	13.0	14.2	—
16"	20.250	21.250	22.250	22.625	—	0.250	1.25	5.00	11.9	13.1	14.4	14.8	—
18"	21.625	23.500	24.125	25.125	—	0.250	1.25	5.00	27.5	32.3	34.0	36.8	—
20"	23.875	25.750	26.875	27.500	—	0.250	1.25	5.00	33.3	38.6	42.0	43.9	—
24"	28.250	30.500	31.125	33.000	—	0.250	1.25	5.00	47.2	53.9	56.0	62.9	—

Bore Tolerances & Drain/Vent Dimensions

Orifice Bore	Plus or Minus Tolerances
Less Than .250"	.001
.250" to .499"	.001
.500" to 1.999"	.0010
2.000" to 3.999"	.0015
4.000" to 9.999"	.0020
10.000" to 19.999"	.0050
20.000" & up	.0100

Orifice Bore	Vent or Drain Hole G
Less Than 1.000"	None
1.000 to 3.500"	3/32"
3.501 to 4.125"	1/8"
4.126 to 5.000"	5/32"
5.001 to 6.000"	3/16"
6.001 to 6.750"	7/32"
6.751 to 7.500"	1/4"
7.501 to 8.375"	9/32"
8.376 to 9.250"	5/16"
9.251 to 10.000"	11/32"
10.0001 to 10.875"	3/8"
10.876 to 11.625"	13/32"
11.626 to 12.500"	7/16"
12.501 to 13.250"	15/32"
13.251" & Larger	1/2"

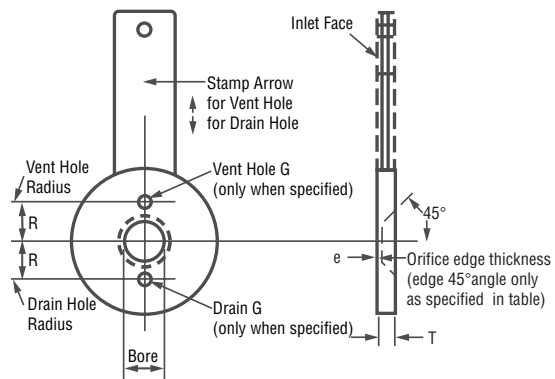

Orifice Edge Thickness

Line Pipe Size	Orifice Edge Thickness E
1/2"—1-1/2"	1/64"
2"—3"	1/32"
3-1/2"—6"	1/16"
8"—12"	1/8"
4"—36"	1/8"



Orifice Plates

Series ORC Flow Type Orifice Plates

When ordering please specify:

- Series Number
- Line Size & Schedule
- Material
- Quantity
- Required Orifice Size

Material

- 316 Stainless Steel
- Hastelloy - Monel
- Other Material Available

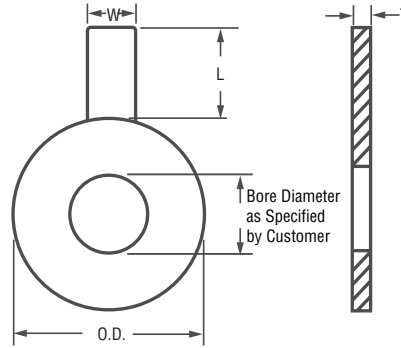

Plates fit ANSI flanges up to 24". Orifice plates for line sizes larger than 24" are available. Consult factory for dimensions.

Line Size	150#	300#	600#	900#	1500#	All Ratings			Weight in pounds - Blank Plate				
	O.D.	O.D.	O.D.	O.D.	O.D.	T	W	L	150#	300#	600#	900#	1500#
1/2"	1.875	2.125	2.125	2.500	2.500	0.125	1.00	4.00	.2	.2	.2	.3	.3
3/4"	2.250	2.625	2.625	2.750	2.750	0.125	1.00	4.00	.3	.3	.3	.3	.3
1"	2.625	2.875	2.875	3.125	3.125	0.125	1.00	4.00	.3	.4	.4	.5	.5
1-1/2"	3.375	3.750	3.750	3.875	3.875	0.125	1.00	4.00	.5	.5	.5	.6	.6
2"	4.125	4.375	4.375	5.625	5.625	0.125	1.00	4.00	.6	.7	.7	1.0	1.0
2-1/2"	4.875	5.125	5.125	6.500	6.500	0.125	1.00	4.00	.8	.9	.9	1.3	1.3
3"	5.375	5.875	5.875	6.625	6.875	0.125	1.00	4.00	1.0	1.1	1.1	1.4	1.5
4"	6.875	7.125	7.625	8.125	8.250	0.125	1.00	4.00	1.5	1.6	1.8	2.0	2.1
5"	7.750	8.500	9.500	9.750	10.000	0.125	1.00	4.00	1.9	2.2	2.7	2.9	3.0
6"	8.750	9.875	10.500	11.375	11.125	0.125	1.00	5.00	2.4	3.0	3.4	3.9	3.7
8"	11.000	12.125	12.625	14.125	13.875	0.125	1.00	5.00	3.6	4.4	4.8	5.9	5.7
10"	13.375	14.250	15.750	17.125	17.125	0.125	1.00	5.00	5.3	6.0	7.3	8.6	8.6
12"	16.125	16.625	18.000	19.625	20.500	0.250	1.25	5.00	8.1	8.6	10.0	11.7	12.8
14"	17.750	19.125	19.375	20.500	—	0.250	1.25	5.00	11.0	11.7	13.0	14.2	—
16"	20.250	21.250	22.250	22.625	—	0.250	1.25	5.00	11.9	13.1	14.4	14.8	—
18"	21.625	23.500	24.125	25.125	—	0.250	1.25	5.00	27.5	32.3	34.0	36.8	—
20"	23.875	25.750	26.875	27.500	—	0.250	1.25	5.00	33.3	38.6	42.0	43.9	—
24"	28.250	30.500	31.125	33.000	—	0.250	1.25	5.00	47.2	53.9	56.0	62.9	—

Bore Tolerances & Drain/Vent Dimensions

Tolerance for Orifice Bore		Orifice Bore	Vent or Drain Hole G
Orifice Bore	Plus or Minus Tolerances		
Less Than .250"	.001	Less Than 1.000"	None
.250" to .499"	.001	1.000 to 3.500"	3/32"
.500 to 1.999"	.0010	3.501 to 4.125"	1/8"
2.000" to 3.999"	.0015	4.126 to 5.000"	5/32"
4.000" to 9.999"	.0020	5.001 to 6.000"	3/16"
10.000" to 19.999"	.0050	6.001 to 6.750"	7/32"
20.000" & up	.0100	6.751 to 7.500"	1/4"
		7.501 to 8.375"	9/32"
		8.376 to 9.250"	5/16"
		9.251 to 10.000"	11/32"
		10.0001 to 10.875"	3/8"
		10.876 to 11.625"	13/32"
		11.626 to 12.500"	7/16"
		12.501 to 13.250"	15/32"
		13.251" & Larger	1/2"



MACHINING & MANUFACTURING LTD.

1-877-MAC-WELD (622-9353)

1324 Lougar Avenue, Sarnia, Ontario N7S 5N7

Tel: (519) 332-1388 Fax: (519) 332-3280

www.mac-weld.com